

Nut Bracket

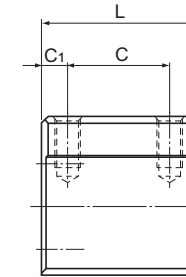
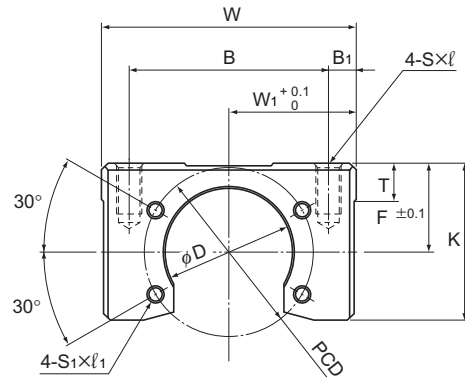

Unit: mm

Model No.	Width		B	B ₁	Overall length L	C	C ₁	F	K	T	D	PCD	S × ℓ	S ₁ × ℓ ₁	For factory automation equipment		Mass kg
	W	W ₁													Supported Ball Screw models		
MC 1004	48	24	40	4	32	16	10	20	32.5	9	26.4	36	M5 × 10	M4 × 7	BNK1004, BNK1010		0.24
MC 1205	60	30	47	6.5	36	24	6	21	37	9	30.4	40	M6 × 12	M4 × 7	BNK1205		0.38
MC 1408	60	30	50	5	36	20	10	21.5	37	9	34.4	45	M6 × 12	M5 × 7	BNK1408, BNK1510, BNK1520, BNK1616		0.34
MC 2010	86	43	70	8	50	30	10	31	54	16	46.4	59	M10 × 20	M6 × 10	BNK2010		1.04
MC 2020	86	43	70	8	40	24	8	28	51	16	39.4	59	M10 × 20	M6 × 10	BNK2020		0.83