

# Model VRT-A Miniature Type (Tapped Base Type)

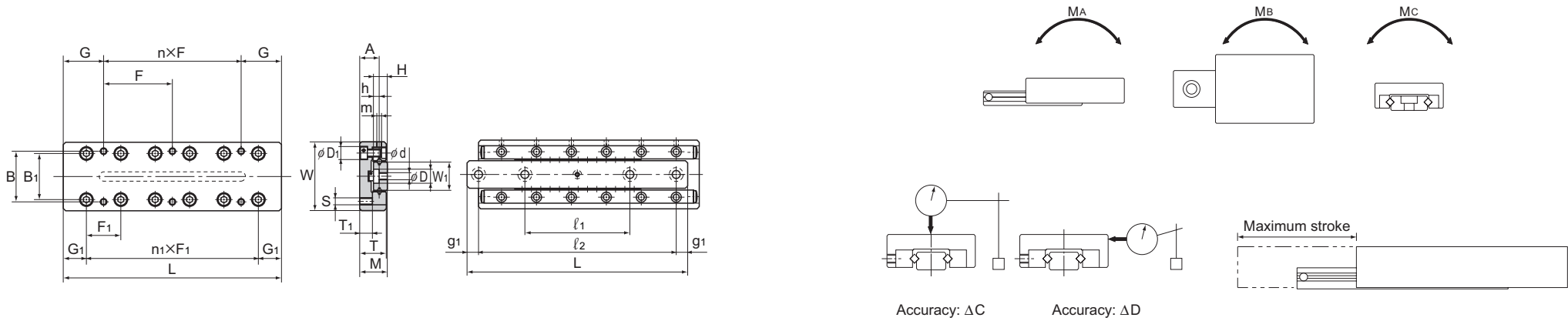

Unit: mm

Model No.	Main dimensions				Table surface dimensions							Side surface dimensions						Base surface dimensions Mounting hole position				Basic load rating			Static permissible moment			Accuracy				
	Maximum stroke	Width W ±0.1	Height M ±0.1	Length L	Mass g	Table mounting tap position				n <sub>1</sub> ×F <sub>1</sub>	B <sub>1</sub>	D <sub>1</sub>	G <sub>1</sub>	T	T <sub>1</sub>	H	W <sub>1</sub>	A	m	d×D×h	l <sub>1</sub>	l <sub>2</sub>	g <sub>1</sub>	No. of rollers Z	C kN	C <sub>0</sub> kN	M <sub>a</sub> N-m	M <sub>b</sub> N-m	M <sub>c</sub> N-m	ΔC	ΔD	
						B	n×F	G	S																							C
VRT 1025A	12	20	8	25	23	14	1×18	3.5	M2.6	1×10	12.4	4.1	7.5	7.5	3.5	4	6.7	5.5	2.5×4.1×2.2	—	18	3.5	5	0.28	0.27	0.75	0.46	0.69	4			
VRT 1035A	18			35	32		1×28	3.5		2×10										—	25	5	7	0.38	0.41	1.23	0.85	1.03				
VRT 1045A	25			45	42		1×20	12.5		3×10										25	38	3.5	10	0.56	0.69	2.18	1.67	1.72				
VRT 1055A	32			55	52		1×30	12.5		4×10										29	48	3.5	12	0.65	0.82	2.97	2.35	2.06				
VRT 1065A	40			65	62		2×20	12.5		5×10										31	55	5	14	0.73	0.96	3.87	3.17	2.4				
VRT 1075A	45			75	72		1×30	22.5		6×10										35	65	5	18	0.87	1.27	6.05	5.16	3.19				
VRT 1085A	50			85	82		2×30	12.5		7×10										40	75	5	20	0.94	1.37	7.32	6.37	3.43				
VRT 2035A	18			30	12		35	78		22										1×28	3.5	M3	1×15	20	6	10	11.5	5.5			6	12.2
VRT 2050A	30	50	113			1×43	3.5	2×15	—		35	7.5	7	0.69	0.76	3.76	2.65	3.32														
VRT 2065A	40	65	147			1×30	17.5	3×15	33		55	5	9	0.85	0.98	5.62	4.22	4.25														
VRT 2080A	50	80	181			1×45	17.5	4×15	40		70	5	12	0.98	1.27	9.1	7.26	5.52														
VRT 2095A	60	95	217			2×30	17.5	5×15	45		85	5	14	1.18	1.57	11.8	9.71	6.8														
VRT 2110A	70	110	254			1×45	32.5	6×15	50		95	7.5	17	1.47	2.06	16.7	14.1	8.93														
VRT 2125A	80	125	287			2×45	17.5	7×15	55		110	7.5	19	1.57	2.25	20.4	17.5	9.77														
VRT 3055A	30	40	16			55	226	30	1×40		7.5	M4	1×25	28.4	7.5	15	15.5	7.5	8	16	11.5		4.5×7.5×4.2						—	40		
VRT 3080A	45			80	333	1×65	7.5		2×25	43	68		6									10		2.16	2.84	22.2	17	16.5				
VRT 3105A	60			105	439	1×50	27.5		3×25	55	90													13	2.94	4.22	34.8	28.1	24.4			
VRT 3130A	75			130	548	1×75	27.5		4×25	65	115		7.5												17	3.63	5.69	55.8	47.1	33.3		
VRT 3155A	90			155	652	2×50	27.5		5×25	95	140														20	3.92	6.37	74.7	64.6	36.9		
VRT 3180A	105			180	761	1×75	52.5		6×25	85	165														24	4.02	6.57	104.3	92.3	38.1		
VRT 3205A	130			205	866	2×75	27.5		7×25	90	190														26	4.22	7.16	120.8	107.9	41.5		

Note) All stainless steel type with high corrosion resistance is also available.

(Example) VRT 2035A M

— Symbol for stainless steel type

Cross Roller Table