

# Model FBL 35M

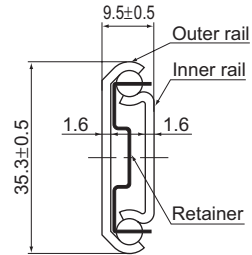
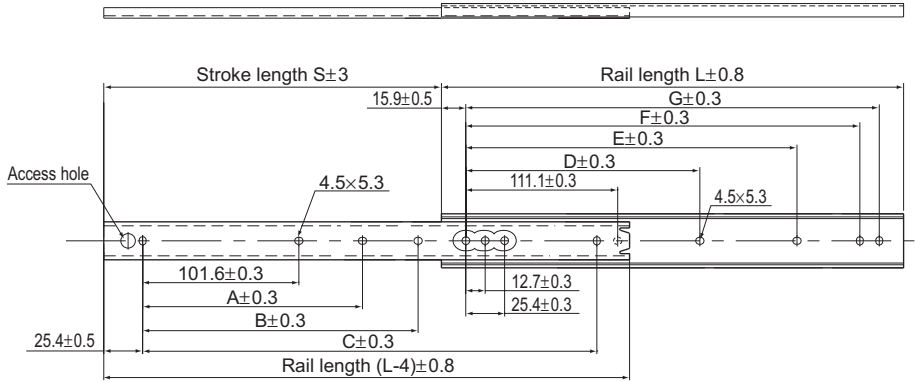

Cross section

Unit: mm

| Rail length L (±0.8) | Stroke S (±3) | Mounting hole dimensions |       |       |       |       |       |       | Mounting hole |            | Permissible load N/pair | Mass kg/pair |
|----------------------|---------------|--------------------------|-------|-------|-------|-------|-------|-------|---------------|------------|-------------------------|--------------|
|                      |               | A                        | B     | C     | D     | E     | F     | G     | Inner rail    | Outer rail |                         |              |
| 305                  | 229           | —                        | 152.4 | 254.0 | —     | 149.2 | 260.3 | 273.0 | 4             | 7          | 490                     | 0.6          |
| 356                  | 279           | —                        | 203.2 | 304.8 | —     | 200.0 | 311.1 | 323.8 | 4             | 7          | 400                     | 0.7          |
| 406                  | 305           | —                        | 254.0 | 355.6 | —     | 250.8 | 361.9 | 374.6 | 4             | 7          | 390                     | 0.8          |
| 457                  | 330           | 203.2                    | 304.8 | 406.4 | 212.7 | 301.6 | 412.7 | 425.4 | 5             | 8          | 380                     | 0.9          |
| 508                  | 381           | 228.6                    | 355.6 | 457.2 | 238.1 | 352.4 | 463.5 | 476.2 | 5             | 8          | 330                     | 1.0          |
| 559                  | 406           | 254.0                    | 406.4 | 508.0 | 263.5 | 403.2 | 514.3 | 527.0 | 5             | 8          | 320                     | 1.1          |
| 610                  | 432           | 279.4                    | 457.2 | 558.8 | 288.9 | 454.0 | 565.1 | 577.8 | 5             | 8          | 310                     | 1.2          |
| 660                  | 483           | 304.8                    | 508.0 | 609.6 | 314.3 | 504.8 | 615.9 | 628.6 | 5             | 8          | 280                     | 1.3          |
| 711                  | 508           | 330.2                    | 558.8 | 660.4 | 339.7 | 555.6 | 666.7 | 679.4 | 5             | 8          | 270                     | 1.4          |

Note) The permissible load and the mass each indicate the value for a pair of 2 units.

**Model number coding**

**FBL35M +406L**

Model number Overall rail length (in mm)

Slide Rail